

A powerful boring machine that can be customized to suit your needs

03 | 2023
BB5



The most powerful boring machine in its class, you'll be amazed at the power and flexibility of the BB5000 Portable Boring Machine.

Exclusive, CLIMAX-patented mounting components provide the flexibility to handle tough boring jobs, even when used in cramped, tight workspaces.

Quick and Easy Setup

- Modular components make setup quick and easy.
- Fast and easy setup using high quality cast-iron set-up cones and spherical bearing mounts.
- Patented spherical bearing mounting system allows quick setup, with up to 5° of bearing misalignment.
- Typical set-up time for an experienced operator is 30 minutes or less.

Powerful

- Up to 650 ft-lbs (881 N·m) of torque at the bar – more than any other portable boring machine in its boring range.
- Specially-designed rotational drive unit provides 4:1 or optional 12:1 or worm gear reduction for increased torque at all speeds

Flexible, High Quality Design

- Through-bar design allows the rotational drive and feed unit to be mounted anywhere along the bar, even separately.
- Patented heavy-duty spherical bearing mounts ensure rigid attachment to the work piece, for more effective machining.

Versatile

- Highly customizable to meet a variety of needs.
- Available in electric, servo, hydraulic, or pneumatic motor configurations.

- Reversible electric motor.
- Fast, easy two-bolt change-out process to switch motors.
- Available in a variety of bar lengths, from 4 - 24 feet (1219.2 – 7315.2 mm).
- Bars are straightened, and have ½ in. or 12 mm square-broached tooling holes.
- Accessories allow the BB5000 to be used for blind boring, line boring, drilling, facing, and valve repair.
- An interface kit allows attachment and quick alignment of the CLIMAX Auto Bore Welders for efficient bore welding.

Compact

- Extremely compact for ease of use in cramped, tight work spaces.
- Drive & Feed can be mounted between bearings for use in even more confined spaces.

BB5000 BORING MACHINE

SPECIFICATIONS

Operating Ranges	
Boring Bar Diameter, Standard	2.25 in. (57.2 mm)
Optional	1.75 in. (44.5 mm)
Optional	1.25 in. (31.8 mm)
Boring Diameter, Standard	2.5 - 12 in. (63.5 - 304.8 mm)
Optional	1.375 - 24 in. (34.9 - 609.6 mm)
Boring Stroke, Max	12, 24, or 36 in. (304.8, 609.6, or 914.4 mm)
Power Options	
Electric: 8 to 160 free speed bar RPM	3.35 Hp (2.5 kW)
Servo: up to 230 free speed bar RPM	4.7 Hp (3.5 kW)
Hydraulic: 10 Hp HPU (240 free speed bar RPM with 60 Hz mains power. 200 free speed bar RPM with 50 Hz mains power)	10 Hp (7.5 kW)
Mounting Options	Single Arm, Double Arm, Universal, ID
Rotational Drive Unit Standard	4:1 gear ratio reduction
Optional	12:1 gear ratio reduction
Set-Up Cones, Standard	2.75 - 12 in. (70.0 - 304.8 mm)
Optional	1.375 - 5 in. (34.9 - 127.0 mm)
Feed Type	Mechanical
Feed Rate per revolution	0 - 0.018 in./rev. (0 - 0.46 mm/rev.)
Measures	
Typical Machine Ship Weight (Typical machine with single arm mounts, set-up cones & hydraulic motor)	444 lbs (201 kg)
Approximate Boring Bar Ship Weight (Includes metal shipping container)	1.48 lbs/in. (0.264 kg/cm)
Shipping Dimensions (Shipped in 2 containers, 3 containers for hydraulic power unit option.)	
Machine W, D, H	52.5 x 27 x 16.5 in. (1334 x 686 x 419 mm)
Bar 72 in. (1828.8 mm) W, D, H	74.5 x 6.5 x 7 in. (1892 x 165 x 178 mm)
HPU [5 or 10 Hp] W, D, H	49.5 x 30.5 x 41 in. (1257 x 775 x 1041 mm)

OPERATIONAL DIMENSIONS

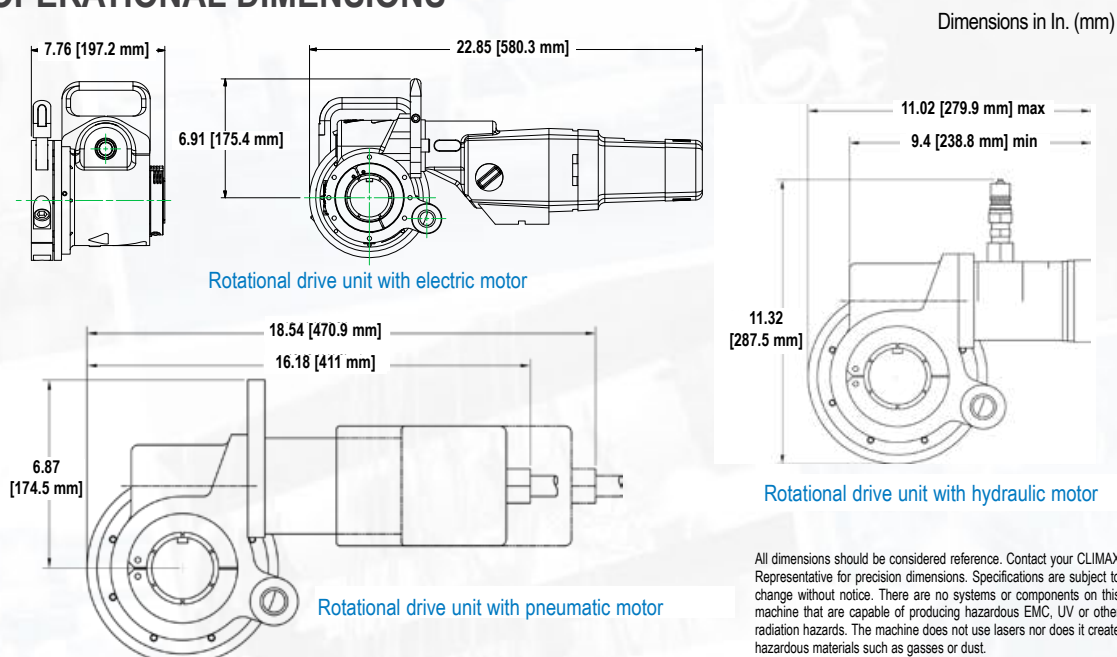

BB5000 BORING MACHINE

OPERATIONAL DIMENSIONS

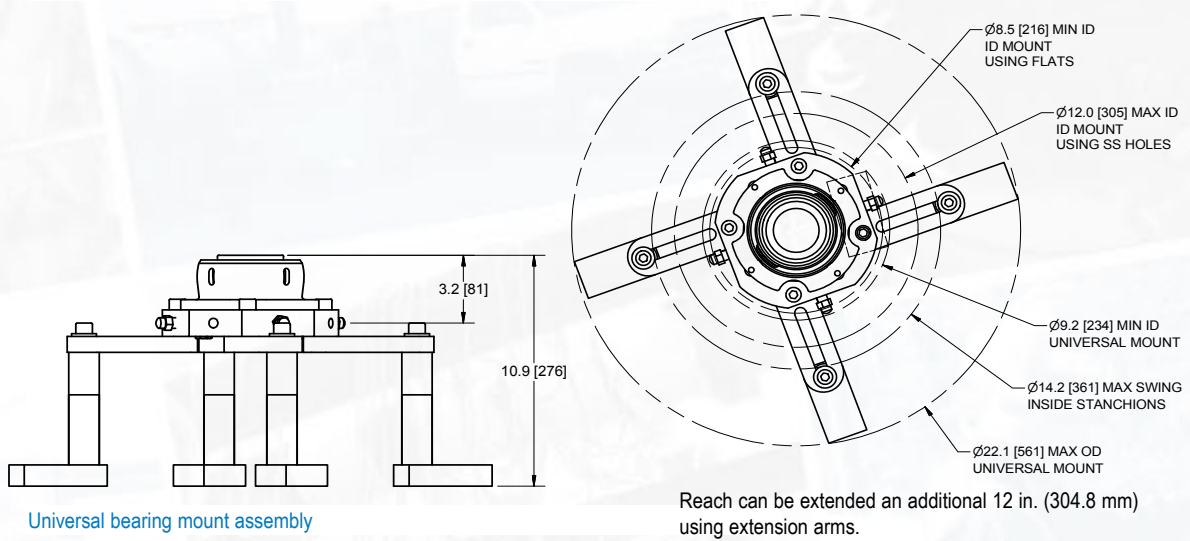
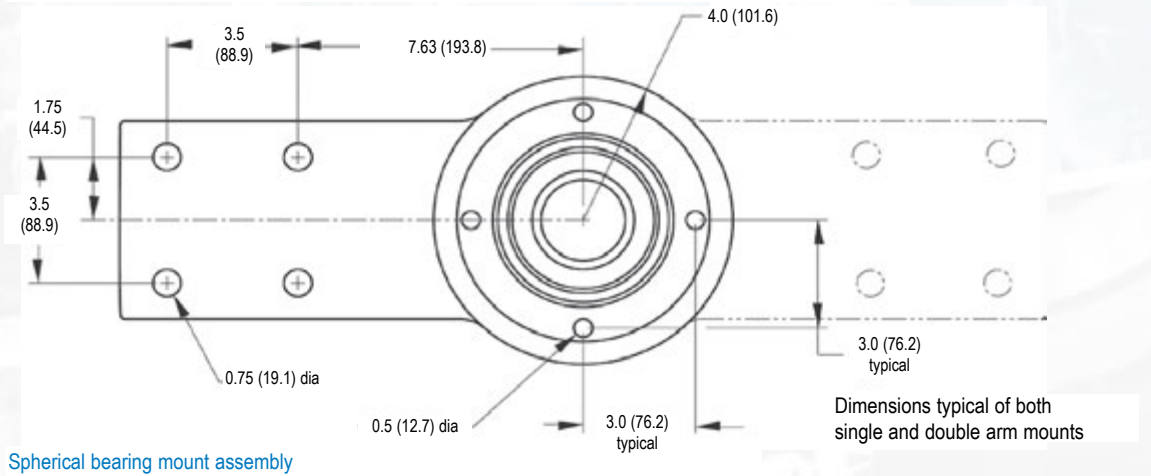
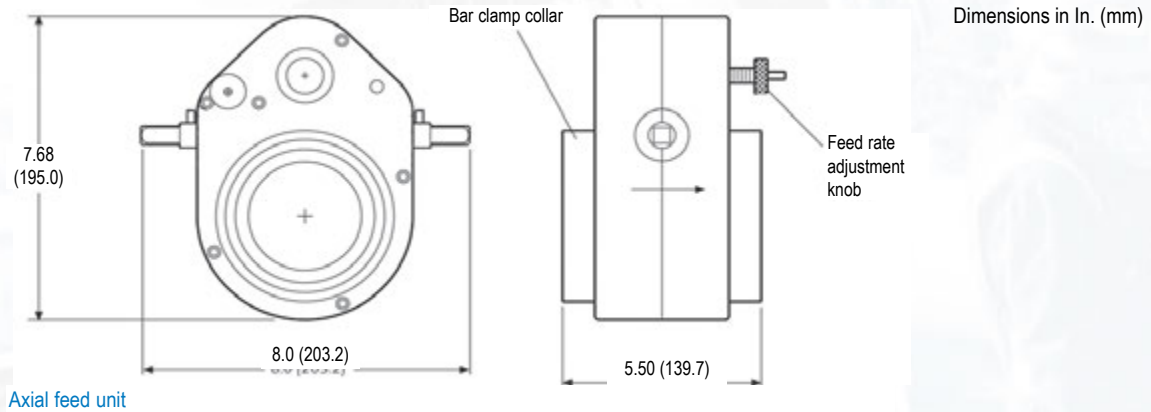

BB5000 BORING MACHINE

TOOL CONFIGURATIONS

Configure your BB5000 in 3 easy steps by selecting:

1. Base Unit
2. Boring Bars

3. Additional Accessories

1. **Base Unit** (Includes RDU 4:1, AFU, Leadscrew, Set Up Cones 2.75 - 12 in. (69.9 - 304.8 mm) Dia., Tool Heads, Tool Kit, Operator's Manual, and Compartmentalized Metal Container)

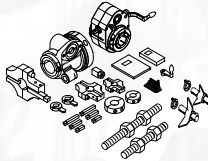

Part Number	Inch/Metric	Motor	Controller	Mounting Option (2-1/4 Bar)	Leadscrew
94085	Inch	Electric, 50/60 Hz, 8/160 bar rpm, 4 speed reversible, 120 VAC (PN 88008)	120V Controller, NEMA L5-30P (PN 88037)	(2) Single Arm Mount (PN 37472) (2) Universal Mount (PN 36959)	12-in. (304.8 mm)
71243	Inch	Not Included - <i>To select a Motor Option go to section 3.</i>	Not Included - <i>To select a Controller Option go to section 3.</i>	(2) Single Arm Mount (PN 37472) (2) Universal Mount (PN 36959)	12-in. (304.8 mm)
104925	Metric	Electric, 50/60 Hz, 8/160 bar rpm, 4 speed reversible, 230 VAC (PN 88009)	230V Controller, CEE 7/7 SCHUKO (PN 88035)	Not Included - <i>To select a Mounting Option go to section 3.</i>	24-in. (609.6 mm)

2. **Boring Bars** All bars are made of 1045 S-CPO chrome-plated steel. Standard bars are available in 2 foot (609.6 mm) increments up to 24 feet (7.3 meters) long, with various hole spacing. After machining, bars are straightened to within 0.001 in. per foot (0.025 per 304.8 mm). Bars come packaged in a fitted steel container with quick-release latches. First hole is 1 in. (25.4 mm) from the end of the bar, for all bar lengths. Morse taper and straight shank holders available upon request.



Configurations shown represent standard options. Please contact us for special fixturing, CNC Control options, or other features that may be needed for your specific machining application. NOTE: Drawings are for reference only, are not to scale, and may not represent actual product.

Bars with In. Tooling				
Holes spaced every 6 in. (152.4 mm)	Holes spaced every 10 in. (254.0 mm)	Bar Diameter	Bar Length	Hole Size
39309	34626	2-1/4 in. (57.2 mm)	48 in. (1219.2 mm)	1/2 in.
39310	34627	2-1/4 in. (57.2 mm)	72 in. (1828.8 mm)	1/2 in.
41552	34628	2-1/4 in. (57.2 mm)	96 in. (2438.4 mm)	1/2 in.
43728	34629	2-1/4 in. (57.2 mm)	120 in. (3048.0 mm)	1/2 in.
43729	34630	2-1/4 in. (57.2 mm)	144 in. (3657.6 mm)	1/2 in.
39308	37337	1-1/4 in. (31.8 mm)	48 in. (1219.2 mm)	3/8 in.
43693	37338	1-1/4 in. (31.8 mm)	72 in. (1828.8 mm)	3/8 in.
39447	37339	1-1/4 in. (31.8 mm)	96 in. (2438.4 mm)	3/8 in.
n/a	37340	1-1/4 in. (31.8 mm)	120 in. (3048.0 mm)	3/8 in.
n/a	37341	1-1/4 in. (31.8 mm)	144 in. (3657.6 mm)	3/8 in.
43311	43318	1-3/4 in. (44.5 mm)	48 in. (1219.2 mm)	1/2 in.
43313	43320	1-3/4 in. (44.5 mm)	72 in. (1828.8 mm)	1/2 in.
43314	43321	1-3/4 in. (44.5 mm)	96 in. (2438.4 mm)	1/2 in.
43315	43322	1-3/4 in. (44.5 mm)	120 in. (3048.0 mm)	1/2 in.
43316	43323	1-3/4 in. (44.5 mm)	144 in. (3657.6 mm)	1/2 in.
Bars with Metric Tooling				
Holes spaced every 6 in. (152.4 mm)	Holes spaced every 10 in. (254.0 mm)	Bar Diameter	Bar Length	Hole Size
43740	34635	2-1/4 in. (57.2 mm)	48 in. (1219.2 mm)	12 mm
43741	34636	2-1/4 in. (57.2 mm)	72 in. (1828.8 mm)	12 mm
43742	34637	2-1/4 in. (57.2 mm)	96 in. (2438.4 mm)	12 mm
43743	34638	2-1/4 in. (57.2 mm)	120 in. (3048.0 mm)	12 mm
43744	34639	2-1/4 in. (57.2 mm)	144 in. (3657.6 mm)	12 mm
43687	37327	1-1/4 in. (31.8 mm)	48 in. (1219.2 mm)	10 mm
43686	37328	1-1/4 in. (31.8 mm)	72 in. (1828.8 mm)	10 mm
43685	37329	1-1/4 in. (31.8 mm)	96 in. (2438.4 mm)	10 mm
n/a	37330	1-1/4 in. (31.8 mm)	120 in. (3048.0 mm)	10 mm
n/a	37331	1-1/4 in. (31.8 mm)	144 in. (3657.6 mm)	10 mm
43298	43305	1-3/4 in. (44.5 mm)	48 in. (1219.2 mm)	12 mm
43307	43300	1-3/4 in. (44.5 mm)	72 in. (1828.8 mm)	12 mm
43301	43308	1-3/4 in. (44.5 mm)	96 in. (2438.4 mm)	12 mm
43302	43309	1-3/4 in. (44.5 mm)	120 in. (3048.0 mm)	12 mm
43303	43310	1-3/4 in. (44.5 mm)	144 in. (3657.6 mm)	12 mm

BB5000 BORING MACHINE

TOOL CONFIGURATIONS

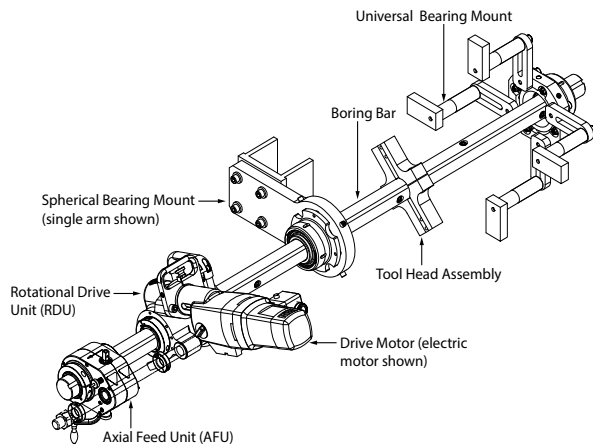

3. Additional Accessories

Drive Motor

Electric, 50/60 Hz, 8/160 bar rpm, 4 speed reversible, CE:

88008 120 VAC

88009 230 VAC

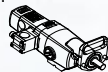

Servo Electric, CE:

54321 230V, Includes 12:1 RDU

52876 460V, Includes 12:1 RDU

56026 230V, Motor Only (Does not include RDU)

56027 460V, Motor Only (Does not include RDU)

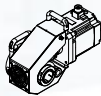

Hydraulic Reversible hydraulic motor and SAE 2-bolt mounting flange to mount to the rotational drive housing. Motor ports are 7/8" - 14 SAE O-ring type. 1/2 in. dripless quick-connect fitting kit installed. Bar rpm's are max at 6 gpm (22.7 L/min). (For 50 Hz power units, reduce the bar rpm by 15%; bar torque remains the same.) Also available with 3/8 in. (9.5 mm) fitting kits

Motor Capacity		Max Bar RPM at		Torque at Bar Calculated ft.-lbs. (N•m)	Part No. Motors with 60 Series QD Fittings	Part No. Motors with ISO 16028 QD Fittings
in ³	cm ³	8.3 gpm (31.5 L/min) with 50 Hz mains power	10 gpm (37.9 L/min) with 60 Hz mains power			
2.2	36	204	246	92 (124.7)	39837	65384
3.6	59	124	150	159 (215.6)	39843	63425
5.7	93.4	76	92	270 (367)	39844	63429
7.3	119.6	60	73	342 (463.7)	39845	69434
8.9	145.8	49	60	417 (565.4)	39846	69435
11.3	185.2	40	49	478 (648.1)	43451	69436
14.1	231.1	31	38	652 (884.0)	39847	69438
17.9	293.3	24	30	764 (1035.8)	43452	69439

Minimum speed is 20% of the maximum speed

Pneumatic The 3 Hp (2.2 kW) motor comes complete, ready for 2-bolt mounting directly on the rotational drive. **Includes pneumatic conditioning unit**

Part Number	Max Bar RPM	Torque at the bar (calculated value)
39112 (non-CE)	120 rpm	115 ft-lb (155.9 N•m)
37498 (non-CE)	57 rpm	234 ft-lb (317.3 N•m)

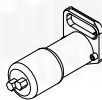

Hydraulic Power Unit

10 Hp (7.5 kW) 10 gpm (37.9 L/min) units with 3-phase electric motor, with variable displacement pump, allow speed control without sacrificing torque. Many models available. Please ask a CLIMAX representative for details.

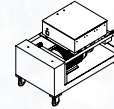

Controller

88037 120V Controller, NEMA L5-30P **

88038 120V Controller, ISO 309/CEE 17, CE Compliant**

88035 230V Controller, CEE 7/7 SCHUKO, CE Compliant **

88036 230V Controller, NEMA L6-15P **

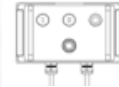

**If a different type of electrical plug is required the end user must replace these standard plugs in the field.

Mounting Options - for 2-1/4 in. dia. bars

37472 Single arm mount assembly (1)

37473 Double arm mount assembly (1)

36959 Universal mount assembly (1)

63535 Universal arm 24 in. (609.6 mm) extension kit

37621 Universal mount ID conversion kit

37626 ID Mount, for 8.6 - 11.2 in. (218.4 - 284.5 mm) diameter.

46293 **Face adjustable ID mount** (1) - Ideal for mounting the BB5000 in deep or blind bores, this ID bearing mount provides an ID mounting range of 5.75 - 12.5 in. (146.1 - 317.5 mm). Easily install and adjust the mount from the open face part of your bore. Independently adjustable mounting legs also simplify centering the mount in bores which are not perfectly round

46227 **Face-adjustable ID bearing mount** 1.5 in. extension jaw to extend reach (need 4)

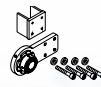

Single arm mount

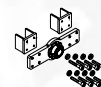

Double arm mount

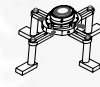

Universal mount



ID mount

20319 **Bearing support assembly** provides 4-way adjustable bar alignment. Fits bores with ID's from 11.5 - 24 in. (292.1 - 609.6 mm). Bar is held in place by a self-aligning bearing. Assembly includes chuck and bearing, three sets of jaws, two sets of jacking screws, and one set of 1 in. (25.4 mm) spacers.



Cantilever mount

28799 Cantilever standoff mounts between two bearing mounting brackets to ensure machine rigidity when blind boring, trepanning, spade drilling, or tapping. Order bearing mounting brackets separately. Order two assemblies when using a double arm mount.

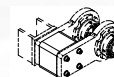

Spherical bearing

26248 Spherical bearing - 2-1/4 in. (57.2 mm). Bearing mounts to bracket to align the bar.

ACCESSORIES

Small Bore Kits Without Bars

- 60654** 1-¼ in. diameter small bore kit includes the following:
- 48999** RDU collet with drive key, AFU collet
 - 26719** (4) bearing collets
 - 26263** set of aluminum set up cones
- 60630** 1-¼ in. diameter small bore kit includes the following:
- 48999** RDU drive collet with drive key, AFU collet
 - 26719** (4) bearing collets
 - 26263** set of aluminum set up cones
 - 26656** 1-¼ in. alignment tool for BoreWelder
- 63933** 1-¾ in. diameter small bore kit includes
- 49001** RDU collet with drive key & AFU collet
 - 26722** (4) bearing collets
 - 43383** Small cast iron set up cones for 1-¾ in. bar
 - 36062** 1-¾ in. alignment tool for BoreWelder

Automated Bore Welders

Add an Automated Bore Welder to your BB5000 Boring Machine with the convenient bore welder interface kit. Attach the bore welder to the BB5000's mounting fixture to ensure perfect alignment for both welding and machining. A single setup for both welding and machining saves time, and helps get the job done quickly. (All bore welders include welding head, torches, mounting rod & radial mount, torch extensions, conduit switch assembly, tips, nozzles, diffuser, and liner. See table below to compare other features & components.)

Bore Welding Interface Kit (See the CLIMAX Bore Welder product literature for details)

- 26518** Complete interface kit for 2-¼ in. (57.2 mm) diameter bar.
- 36062** Alignment tool only for 1-¾ in. (44.5 mm) diameter bar.
- 26656** Alignment tool only for 1-¼ in. (31.8 mm) diameter bar.

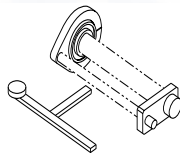

Model.	Welding Dia In. (mm)	Facing Torch Option	Wire Feeder Included	Auto-Skip Included
BW1000	0.88 - 12.0 (22.4 - 304.8)	No	No	No
BW2600	0.88 - 5 in. (22.4 - 127)	Yes	Yes	Yes
BW3000	0.88 - 13.0 (22.4 - 330.2)	Yes	Yes	Yes

BW1000 Auto Bore Welder

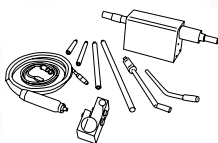

BW3000 Auto Bore Welder

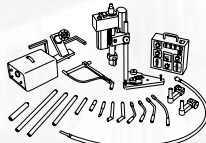

Mechanical Axial Feed Assembly

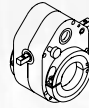

Mounts anywhere on the bar. Reversible ratchet feed mechanism has variable feed rate up to 0.19 in. (0.48 mm) per revolution. Feeds the tool and bar by moving along the stationary leadscrew. Adjustable clamp collars on both ends clamp unit to the bar. Includes auto stop.

The **High-Speed AFU** is designed with heavier springs and minimal mass cam arms to work at higher speeds, for example, greater than 200 rpm bar speed. Recommended for use with the servo-powered RDU. **Note that the standard AFU small bore collets will not work with the High-Speed AFU.**

- 28636** Standard AFU for 2-¼ in. (57.2 mm) diameter bar.
- 91518** High-Speed AFU for 2-¼ in. (57.2 mm) diameter bar

Rotational Drive Assembly

Mounts anywhere on the bar. Features heavy-duty cast aluminum housing, Timken roller bearings, and sealed, lifetime lubrication. Clamp ring mounts assembly to spherical bearings with one bolt.

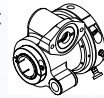

Part Number.	Generation	Worm Gear Reduction	Accepts Bar Dia.	Key Size
49684	4th	4:1	2-¼ in.	⅜ in.
53165	4th	12:1	2-¼ in.	⅜ in.

Axial Leadscrew Assembly

Stationary leadscrew assembly is fixed in position by screwing it into the rotational drive assembly or into tack weld mounting block. Acme nut holds leadscrew in place. Includes leadscrew and two Acme nuts.



Leadscrews available in lengths below. Other lengths available by request.

- 28654** 12 in. (304.8 mm) travel
- 28687** 24 in. (609.6 mm) travel
- 28688** 36 in. (914.4 mm) travel
- 39335** 48 in. (1219.2 mm) travel
- 28756** Leadscrew tack weld block

Set-Up Cones

Cones slide onto the bar and into fairly round, in-line holes for fast set-up. Set screws and back-up clamp collars hold the cones in place while the components are being attached.



- 26263** Set of 2 aluminum set-up cones, 1.5 - 3.25 in. (38.1 - 82.6 mm) bore ID. Fit 1-¼ in. (31.8 mm) diameter bars.
- 26507** Set of 2 cast iron set-up cones for 2.75 - 8.37 in. (69.9 - 212.6 mm) bore ID. Fit 2-¼ in. (57.2 mm) diameter bars.
- 26508** Set of 2 cast iron set-up cones for 8.37 - 12 in. (212.6 - 304.8 mm) bore ID. **Fit 2-¼ in. (57.2 mm) diameter bars.**
- 26383** Full set of cast iron set-up cones for 2.75 - 12 in. (69.9 - 304.8 mm) bore ID. **Fit 2-¼ in. (57.2 mm) diameter bars.**

NOTE: Drawings are for reference only, are not to scale, and may not represent actual product.

ACCESSORIES

Accessories for Drilling and Blind Hole Boring

Turn your BB5000 into a powerful drilling system with the following accessories. A wide array of options available, please talk to us about your needs - we can customize a package to fit your specific need.

Drill Base

57140 Includes drill stand with grip tight bearing, tack weld spacers and all hardware. Customer will need to order #4 or #5 Morse Taper or straight shank bar (1), single arm bearing mount and drill tooling as well as BB5000 drive and feed to make a complete drill package

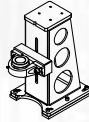

Morse Taper and Straight shank bars

CLIMAX sells special bars for drilling and blind hole boring. Options include #4 and #5 Morse Taper and bars with Morse Taper on one end and 1.25" straight shank on the opposite end. For most applications we recommend the #4 Morse Taper. The majority of our drilling and blind hole boring tooling is supplied with #4 Morse Taper.



2-1/4 In. (57.2 mm) diameter Bars for Drilling and Blind Hole Boring				
Bar Length In. (mm)	#4 Morse Taper only	#4 Morse Taper and straight Shank	#5 Morse Taper only	#5 Morse Taper and Straight Shank
24 (609.6)	58828		19282	18715
36 (914.4)	36114	61459	19283	18716
48 (1219.2)	38277	61502	19284	18717
60 (1524.0)	58827		19285	18718
72 (1828.8)	36113	61503	21131	58820
96 (2438.4)	38278	61504	19286	58821
144 (3657.6)	34200			

Coolant Mister

56524 Supplies Cooling Mist Directly to the Cutting Edge through the Super Drill or Allied Machine & Tool RCA (Rotary Coolant Adapter)

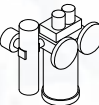

59804 New-Lube Coolant, 1 gallon

Super Drill

57629 Kit A1 1.968 - 2.165 in. (50 - 55 mm) #4 Morse taper

57647 Kit A2 2.165 - 2.559 in. (55 - 65 mm) #4 Morse taper

57652 Kit B 2.559 - 3.149 in. (65 - 80 mm) #4 Morse taper

57661 Kit C 3.149 - 3.937 in. (80 - 100 mm) #4 Morse taper

57667 Kit D 3.937 - 4.724 in. (100 - 120 mm) #4 Morse taper

57692 SBG Sharpening Fixture - See the CLIMAX Drilling & Blind Hole Boring supplement for a complete listing of insert, drill components and accessories

Criterion

59767 CB-203D 3 in. (76.2 mm) diameter boring head kit

59768 CB-204D 4 in. (101.6 mm) diameter boring head kit

Bore Measuring Tool

Features a fine adjustment feature which allows precision bore measurement and sets tool bit height while the bar is still mounted in the work piece.

70645 Mounts on any bar from 1-1/4 to 2-1/4 in. (31.8 to 57.2 mm) in diameter. Measures up to 12 in. (304.8 mm) diameter bores.

79151 Thin stylus, mounts on any bar from 1-1/4 to 2-1/4 in. (31.8 to 57.2 mm) in diameter. Measures up to 12 in. (304.8 mm) diameter bores.

67487 Mounts on any bar from 1-1/4 to 2-1/4 in. (31.8 to 57.2 mm) in diameter. Measures up to 24 in. (609.6 mm) diameter bores.



Magnetic Back Dial Indicator

Top quality travel dial indicator with magnetic back, made by Starrett® for CLIMAX. Useful for many things including:

- Precisely setting depth of cut.
- Measuring and setting boring bar travel when cutting to a shoulder.
- Facing operations, precision alignment of boring bar to larger bores.

45396 0 - .500 in. range (.001 increment) - white face

45397 0 - 10 mm range (.01 mm increment) - yellow face

Digital Bore Measuring Caliper

Get an accurate reading of the bore without removing the bar. Features locking, micro-adjust slide.

61707 Measures up to 10 in. (254.0 mm) ID/OD

63330 Measures up to 24 in. (609.6 mm) ID/OD



Boring Heads

Boring heads may be positioned anywhere along the bar. Split body allows attachment without moving the bar. Boring heads to fit 2.0 in. (50.8 mm) diameter bars also available.

11817 **HSS-in. boring head set** (included in base Unit 49003) Has (5) boring heads to bore 4.5 - 12 in. diameter

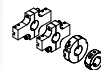

34565 **HSS-metric boring head set** (included in base Unit 49004) Has five boring heads to bore 114.3 - 304.3 mm diameter. Uses standard 10 mm & 12 mm square cutter.

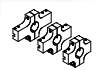

16161 **Boring head set** Has boring hub and boring head arms to bore 12 - 24 in. (304.8 - 609.6 mm) diameter.



NOTE: Drawings are for reference only, are not to scale, and may not represent actual product.

BB5000 BORING MACHINE

ACCESSORIES

Tool Kits

Complete set of tools for the boring bar (included in base unit)

28784 Tool kit (In.)

34580 Tool kit (Metric)

Tool Holder Kit

56275 Tool holder kit complete set (L/R/neutral) with five 80 degree diamond inserts with 1/2 in. square shank



Proper maintenance and repair of your equipment is crucial to its performance, safety, uptime, and longevity.

Preventative Maintenance Kit: 97276

An assortment of recommended spare parts needed over the next 2 years.



AFU service kit (1), 2-1/2 ID clamp collar split hinged (4), Crank Handle (1), 1/4 key (1), 1-5 ACME nut (2), SHCS 1/2-13 X 1-1/2 screw (2), SHCS 1/2-13 X 2 screw (8), SSSFP 1/2-20 X 2 screw (4), SHCS 3/8-16 X 1 screw (2), SSSCP 3/8-16 X 3/4 screw (4), HHCS 5/16-24 X 2 screw (4), SHCS 5/8-11 X 2-1/2 screw (4), single carbon brush for Eibenstock (2), tool bag (1), hardened 1/2 FLTW hardened washer (8), hardened 5/16 FLTW washer (4), hex wrench (1)

Tool Bits

Size	RH/LH	Degree	Part Number
HSS Standard tool bits (in.)			
1/2 x 1 in.	LH	5° lead*	31866
1/2 x 1 in.	LH	0° lead*	31857
1/2 x 1.8 in.	LH	15° lead*	31867
1/2 x 1.8 in.	LH	0° lead*	31858
1/2 x 2.5 in.	LH	15° lead*	32344
1/2 x 2.5 in.	LH	0° lead*	32342
1/2 x 4 in.	LH	15° lead*	31868
1/2 x 4 in.	LH	0° lead*	31859
1/2 x 2.5 in.	LH / RH	double-ended	25710
HSS Tool bits (Metric)			
12 mm x 1 in. (25.4 mm)	LH	0° lead**	34574
12 mm x 1.8 in. (45.7 mm)	LH	15° lead**	34578
12 mm x 1 in. (25.4 mm)	LH	0° lead**	34579
12 mm x 1.8 in. (45.7 mm)	LH	0° lead**	34573
12 mm x 2.5 in. (63.5 mm)	LH	15° lead**	34577
12 mm x 2.5 in. (63.5 mm)	LH	0° lead**	34572
12 mm x 4 in. (101.6 mm)	LH	15° lead**	34576
12 mm x 4 in. (101.6 mm)	LH	0° lead**	34571
HSS Alternative tool bits			
1/2 x 1 in.	RH	15° lead	31848
1/2 x 1 in.	RH	0° lead	31830
1/2 x 1 in.	RH	0° lead side cutting	32103
1/2 x 1 in.	LH	0° lead side cutting	32114
1/2 x 1.8 in.	RH	0° lead	31831

Size	RH/LH	Degree	Part Number
HSS Alternative tool bits continued			
1/2 x 1.8 in.	RH	0° lead side cutting	32104
1/2 x 1.8 in.	LH	0° lead side cutting	32115
1/2 x 2.5 in.	RH	15° lead	32345
1/2 x 2.5 in.	RH	15° lead	32345
1/2 x 2.5 in.	RH	0° lead	32343
1/2 x 2.5 in.	RH	0° lead side cutting	32341
1/2 x 2.5 in.	LH	0° lead side cutting	32340
1/2 x 4 in.	RH	5° lead double-ended	31850
1/2 x 4 in.	RH	5° lead double-ended	31841
1/2 x 4 in.	RH	0° lead side cutting	32105
1/2 x 4 in.	LH	0° lead side cutting	32116
1/2 x 4 in.	LH	15° lead double-ended	34348
Twin leadscrew facing head tool bits			
1/2 x 4 in. (HSS)	LH	15° lead	31868
1/2 x 3.5 in. (Carbide)	LH	15° lead	31917
HSS Facing/Grooving tool facing bits			
1/2 x 1.8 in.	RH	15° lead	31849
1/2 x 1.8 in.	RH	0° lead	31831
Bits (1 each)		15° lead and 0° lead	36370
0.12 in. wide	LH	15° lead top rake	35948
0.12 in. wide	LH	0° lead top rake	37766
0.56 in. wide,	LH	15° lead top rake	35949
0.56 in. wide,	LH	0° lead top rake	37767

* Included in tool kit 28784 ** Included in tool kit 34580

NOTE: Drawings are for reference only, are not to scale, and may not represent actual product.

BB5000 BORING MACHINE

GET THE MOST OUT OF YOUR MACHINE

Customers who bought the **CLIMAX BB5000 Line Boring Machine** also bought the below products:

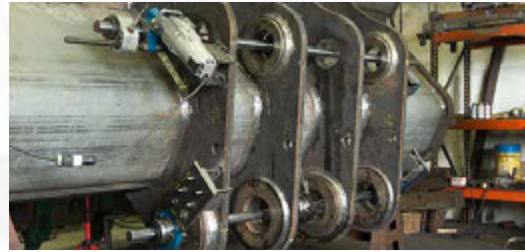

BW1000 AUTO BORE WELDER

Highly portable and easily affordable automated spiral welding system.

Part # 70594



BW2600 AUTO BORE WELDER

Interfaces directly with users existing MIG Wire feed systems.

Part # 86686



BW3000 AUTO BORE WELDER

Automated step welding system provides you with a new degree of welding performance and precision.

Part # 85680



DIGITAL BORE MEASURING CALIPER

Get accurate bore readings without removing the bar.

Part # 61707



BORE MEASURING TOOL

Quick and easy way to accurately measure the bore and tool bit.

Part # 79151



FACING & GROOVING TOOL

For machining end flanges, or precision grooves.

Part # 36936 36954



ADJUSTABLE RANGE FACING HEAD

Broad facing diameter range from 2.5 - 18 in. (63.5 - 457.2 mm).

Part # 31412 30051 30044



HEAVY DUTY FACING HEAD

Broad facing range, from 2.25 to 24 in. (57.2 - 609.6 mm) without repositioning.

Part # 45040 60301



RIGHT ANGLE BASE ASSEMBLY

Base assembly for drilling and blind hole boring system.

Part # 57140



OPTICAL ALIGNMENT

Simple and accurate way to align many CLIMAX machines.

Part # 62226



SMALL BORE KIT

An easy way to convert your 2.25-in. drive down to a 1.25-in. bar, allowing you to machine in smaller bores.

Part # 60654



LARGE BORE HEAD SET 12 - 24 in. (305 - 610 MM)

Boring heads may be positioned anywhere along the bar.

Part # 16161

SETUP AND OPERATION

Six Step Setup and Operation

Setup of the BB5000 Portable Boring Machine is quick and easy. An experienced operator can set up the machine in most typical two-bore line boring applications in about half an hour (depending on alignment tolerances). The three main ingredients of the quick setup system are:

- Setup cones to roughly center the bar in the bore.
- Spherical mounts that can be quickly tack-welded in place.
- Quick-mount rotational drive unit, attaches to spherical mount in seconds

STEP 1

Slide the bar through the two holes to be bored and roughly center it with the set-up cones. The set-up cones are forced into the bore with the clamp ring jacking screw and locked onto the bar with a set screw.

Elapsed time: 4 minutes.



STEP 4

Slide the rotational drive onto the bar. Firmly push it onto the spherical mount, and lock it in place with one bolt. Tighten the rear clamping collar enough to be snug but so the bar can slide through it.

Elapsed time: 4 minutes.



STEP 2

Slide on spherical mounts with tack weld plates, and tack weld them to the work-piece. These mounts have spherical bearings so they can be mounted up to 5° out of perpendicular alignment.

Elapsed time: 10 minutes.



STEP 5

The axial feed unit is slipped onto the bar and the lead-screw is screwed into the pocket on the rotational drive unit. Tightening two clamping collars locks the axial feed unit to the bar.

Elapsed time: 3 minutes.



STEP 3

Remove the set-up cones and replace the bar. The set-up cones will adequately center the bar, unless you have very precise tolerances, or need to move the centerline of the bore slightly. Final centering adjustments are made with the jacking screws.

Elapsed time: 5 minutes.



STEP 6

Insert a properly ground tool bit into the tool hole in the bar, adjust for depth of cut, and lock in place with the set screw. Connect to power source. Elapsed time: 5 minutes.

And there you are... ready to begin the first boring pass.



Total elapsed time: 31 minutes.

BB5000 BORING MACHINE

APPLICATION PHOTOS

A Wide Variety of Applications

Do you need to put the axial feed unit on one end of the bar and the rotational drive on the other? No problem... all you need to do is use the leadscrew block clamped or tack welded to the work piece. In fact, just about any arrangement of components can be used as long as you maintain rigidity by placing bearing supports as close as possible to the holes to be bored. Need to align and multiple holes? Just use a long bar and weld a bearing bracket at each hole for support or use optical alignment for easy & precise setup over long distances. Modular components let you use the machine in a wide variety of combinations.

The BB5000 is widely used by these industries:

- Construction
- Mining
- Power Generation
- Ship building
- Transportation
- Petrochemical
- Pulp and paper
- Steel and aluminum



Typical Applications:

Heavy equipment repair, Stern tube boring, Wicket gate repair on dams, Bridge building/re-building, Turbine coupling boring, Engine block repair, Bearing seat repair, Press repair, Valve body boring, Pump body boring, Large fab bore alignment.

Whether it's conventional boring, line boring, drilling, facing or grooving, the CLIMAX BB5000 has you covered. With versatile setup & machining options, it's the machine you need to get all your toughest jobs done when and where you need it.

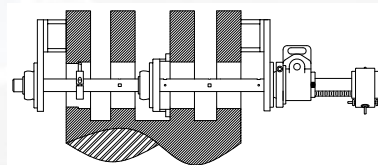

Line Boring

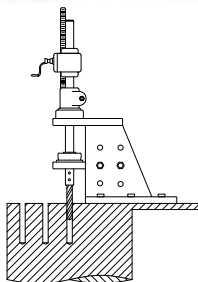

Drilling

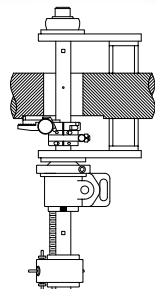

Facing

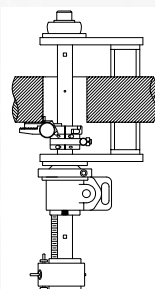

Grooving

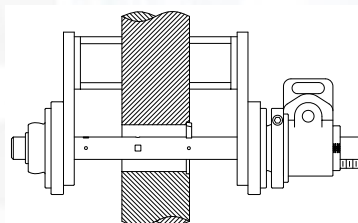

Conventional Boring

BB5000 BORING MACHINE